

# L/S80MC PISTON CROWN CHECK SHEET(CASTING TYPE)

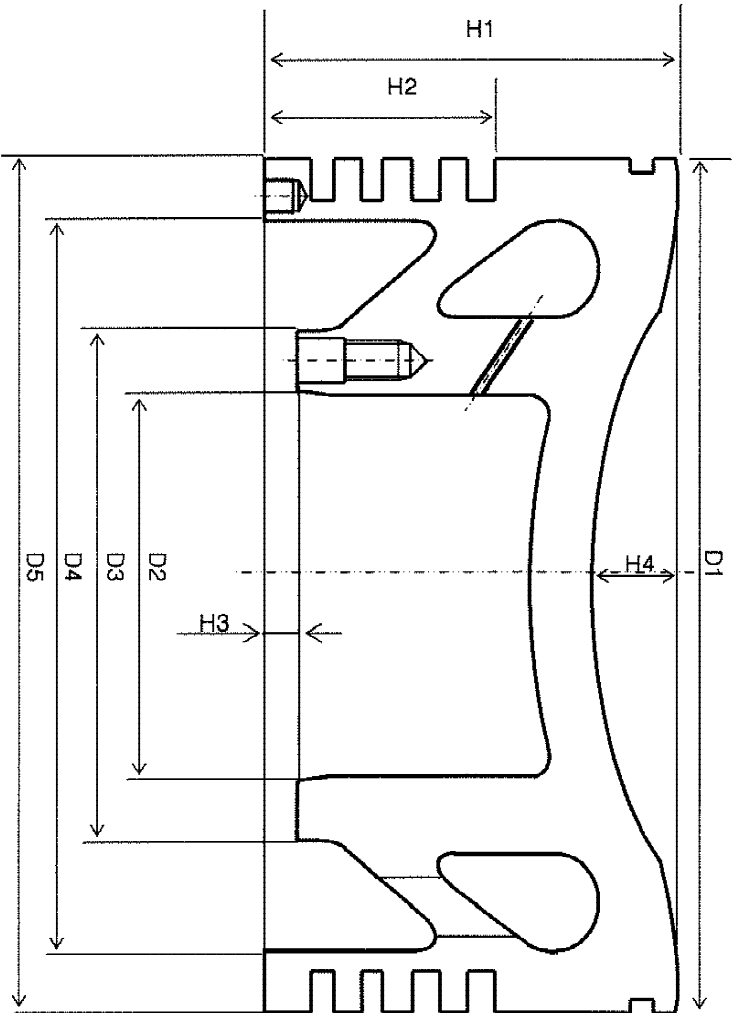
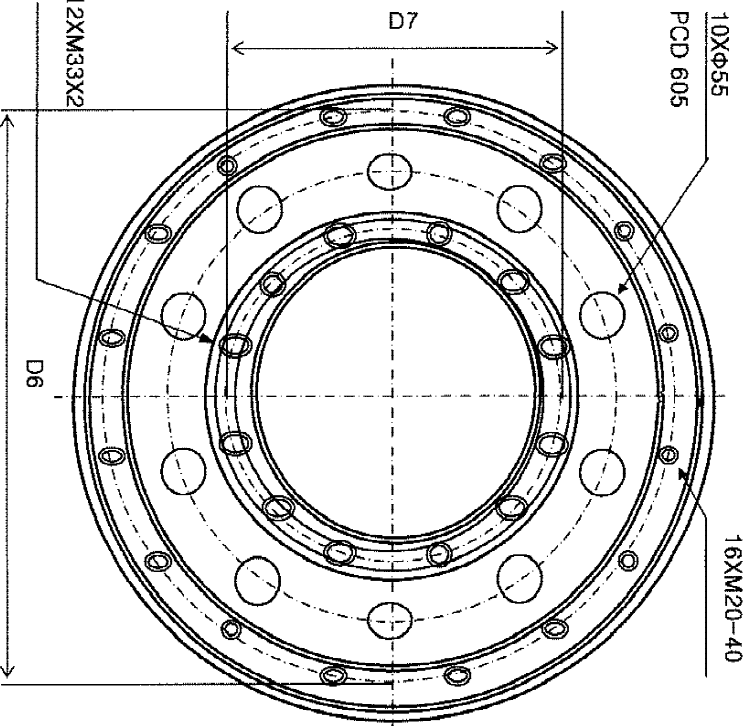

G1  
G2  
G3  
G4

POSITION	D1	D2	D3	D4	D5	D6	D7	H1	H2	H3	H4
DWG. SPEC.	φ793	φ390	φ515	φ690	φ798	φ730	φ460	345	200	30	97

## REMARK) (Other check point)

1. Shape of cooling Hole( To be decided Casting type OR Bore cooled type)
2. Dimension of Ring Groove(ALL 14mm)
3. Without inconel coating